

# **VILLAGE OF MINOOKA**

## **Construction Standards and Specifications For Water System**

### **General Provisions**

The water system shall be constructed in accordance with the requirements of Federal and State statutes or regulations; Illinois Environmental Protection Agency Regulations; the requirements of the Standards Specifications for Water and Sewer Main Construction in Illinois. Latest edition; and the Recommended Standards for Water works, latest edition; Subdivision Regulations for the Village of Minooka; in addition, the following specifications shall apply:

#### **IL EPA Construction Permit**

An approved Illinois Environmental Protection Agency Permit to construct new Public Water Main Extension must be submitted to the IL EPA. The Superintendent of Public Works must receive the permit authorizing construction of the water system before construction begins.

#### **General**

All material shall be manufactured in the United States of America. A Letter of Certification of the country of origin will be provided if requested by the Village.

#### **Watermain Coordination and Staging**

The contractor shall coordinate all work on watermain systems with the Village of Minooka. Construction shall be staged to maintain service to adjacent properties. Temporary system shutdowns shall be of short duration and have prior written approval from the Village of Minooka of the time of day and duration.

No disconnection from existing or connection to proposed is to be performed until the new watermain is tested and placed into service and all work shall be performed prior to abandoning the existing watermain. Notification of interruption of service shall be made to those affected by the Contractor in writing a minimum of 24 hours in advance.

Prior to any work on the water system, requiring a shut-down, the dimension of the existing main shall be verified to assure proper sizing of new fittings. All watermain work shall be coordinated to limit the number of shut-downs to one and minimize the duration of the shut-down.

Procedures in the IEPA Sample Collectors Handbook shall be followed.

## **Watermain**

Watermain shall be ductile iron, Class 52, in accordance with AWWA latest standard, or Polyvinyl chloride (PVC) pressure pipe that shall conform to A.W.W.A. Standard C-900-89 (DR25-C900 for (14"-24" dia. PVC pipe)) and shall be installed in accordance with the manufacturer's instructions. All ductile watermain shall be bituminous coated with cement lining in accordance with AWWA latest standard.

Joints shall be push-on in accordance with AWWA latest standard, except gaskets shall be neoprene or other synthetic rubber.

Ductile iron water main shall be encased in 8-millimeter B-Bio enhanced polyethylene encasement.

Whenever river crossing pipe is required, provide restrained joint, or ball and socket type joints allowing 15 degrees maximum deflection.

## **Tracer Wire for PVC**

In addition to tracer wire taped to the top center of the watermain every 8-10ft warning tape shall be installed 1ft above pipe.

Open Trench - Trace wire shall be coated, #12 AWG Copper Clad Steel, High Strength with minimum 450 lb. break load, with minimum 30 mil HDPE insulation thickness, blue in color. Copperhead #12 High Strength part # 1230

Directional Drilling/Boring - Trace wire shall be coated, #12 AWG Copper Clad Steel, Extra High Strength with minimum 1,150 lb. break load, with minimum 30 mil HDPE insulation thickness, blue in color. Copperhead Extra High Strength part # 1245

Trace wire – Pipe Bursting/Slip Lining - Trace wire shall be coated, 7 x 7 Stranded Copper Clad Steel, Extreme Strength with 4,700 lb. break load, with minimum 50 ml HDPE insulation thickness, blue in color. Copperhead SoloShot Extreme Strength 7 x 7 Stranded part #PBX-50

All mainline trace wires must be interconnected in intersections, at mainline tees and mainline crosses. At tees, the three wires shall be joined using a water tight, single 3-way lockable connector. At Crosses, the four wires shall be joined using a water tight, 4-way connector. Use of two 3-way connectors with a short jumper wire between them is an acceptable alternative.

Direct bury wire connectors – shall include 3-way water tight lockable connectors and mainline to lateral lug connectors specifically manufactured for use in underground trace wire installation. Connectors shall be dielectric silicon filled to seal out moisture and corrosion, and shall be installed in a manner so as to prevent any uninsulated wire exposure. Copperhead 3-way locking connector part # LSC1230 or DryConn 3- way Direct Bury Lug: Copperhead Part # 3WB-01

All trace wire termination points must utilize an approved trace wire access box (above ground access box or grade level/in-ground access box as applicable), specifically manufactured for this purpose.

All grade level/in-ground access boxes shall be appropriately identified with “water” cast into the cap and be the color blue.

A minimum of 2 ft. of excess/slack wire is required in all trace wire access boxes after meeting final elevation.

All trace wire access boxes must include a manually interruptible conductive/connective link between the terminal(s) for the trace wire connection and the terminal for the grounding anode wire connection. Non-Roadway access boxes applications:

Trace wire access boxes Grade level Copper head adjustable lite duty Part # LD14\*TP

Concrete Driveway access box applications: Trace wire access boxes Grade level Copperhead Part # CD14\*TP 14”

Fire hydrant trace wire access box applications: Above ground two terminal Cobra Test Station, denoting “F” includes hydrant mounting flange. Copperhead part # T2\*-FLPKG-5/8to fit hydrants with 5/8” bolts and T2\*-FLPKG-3/4 to fit hydrants with 3/4” bolts.

Grounding anode wire shall be connected to the identified (or bottom) terminal on all access boxes. Drive in Magnesium Anode: Copperhead Part # ANO-12 (1.5 lb)

Service Laterals on public property - Trace wire must terminate at an approved grade level/inground trace wire access box, located at the edge of the road right-of-way, and out of the roadway.

Service Laterals on private property - Trace wire must terminate at an approved above-ground trace wire access box, affixed to the building exterior directly above where the utility enters the building, at an elevation not greater than 5 vertical feet above finished grade, or terminate at an approved grade level/in-ground trace wire access box, located within 2 linear feet of the building being served by the utility.

Hydrants – Trace wire must terminate at an approved above-ground trace wire access box, properly affixed to the hydrant grade flange. (affixing with tape or plastic ties shall not be acceptable)

Long-runs, in excess of 500 linear feet without service laterals or hydrants - Trace wire access must be provided utilizing an approved grade level/in-ground trace wire access box, located at the edge of the road right-of-way, and out of the roadway. The grade level/in-ground trace wire access box shall be delineated using a minimum 48” polyethylene marker post, color coded per APWA standard for the specific utility being marked.

Trace wire must be properly grounded at all dead ends/stubs

Grounding of trace wire shall be achieved by use of a drive-in magnesium grounding

anode rod with a minimum of 20ft of #12 red HDPE insulated copper clad steel wire connected to anode (minimum 1.5 lb.) specifically manufactured for this purpose, and buried at the same elevation as the utility.

When grounding the trace wire at dead ends/stubs, the grounding anode shall be installed in a direction 180 degrees opposite of the trace wire, at the maximum possible distance.

When grounding the trace wire in areas where the trace wire is continuous and neither the mainline trace wire or the grounding anode wire will be terminated at/above grade, install grounding anode directly beneath and in-line with the trace wire. Do not coil excess wire from grounding anode. In this installation method, the grounding anode wire shall be trimmed to an appropriate length before connecting to trace wire with a mainline to lateral lug connector.

Where the anode wire will be connected to a trace wire access box, a minimum of 2 ft. of excess/slack wire is required after meeting final elevation.

After completion of the project, the Village will have performed a trace test on the entire installation, and deficiencies will be noted and must be repaired by the Contractor at their cost.

### **Service Lines**

All service lines shall be one continuous run from B-box to the interior of the building.

A minimum of a one-inch (1") service line shall be required for each single-family residence.

Shall be identified both by a four by four placed alongside the B-box which extends four feet (4') above finished grade painted blue, and by a "W" stamped on the curb.

A two family dwelling (duplex) shall have an individual one-inch (1") service line for each dwelling unit along with individual B-boxes.

For a single family attached, detached dwellings, and commercial and institutional buildings or unit one-inch (1") service line for each dwelling unit shall be provided along with individual B-boxes or a single service line run to a mechanical room is allowed.

Service piping shall be Type K, copper water tube, soft temper conforming to ASTM latest standard with compression fittings.

Maximum service depth is sixty-six inches (66"). Minimum service depth is fifty-four inches (54") from the proposal finished elevation.

If a dwelling or building requires a fire service line then the fire service line shall be valved. Domestic services shall be tapped onto the fire service. A separate shut off for the domestic is at the option of the dwelling or building owner. Fire service lines shall be equipped with a OMNI Fireline water meter.

All B-boxes or shut off valves for service lines shall be located in easement or dedicate public right- of-way.

### **Fire Hydrant**

All fire hydrants shall have a five and one quarter inch (5 ¼") main valve opening.

Hydrant color shall be yellow.

Hydrant paint coating shall be from manufacturer for new hydrants.

The hydrant shall be for a five and one half foot (5 ½') bury depth.

Hydrant shall have two (2) two and one half inch (2 ½") hose connections and one (1) four and one half inch (5") storz connection.

Threads shall be National Standard on the side ports and storz on the steamer port.

The hydrant shall have a breakaway traffic flange and connections.

Hydrant shoes shall be either six inch (6") mechanical joint or flanged depending on the application.

Hydrant leads may be six inch (6") swivel anchoring coupling. Hydrant tees shall be used in lieu of swivel anchoring coupling pipe if necessary.

All fire hydrants not in service shall be bagged or identified with signage.

Four and one half inch (4 ½") connection Storz connections are required on all private fire suppression fire hydrants.

All hydrant lateral bell joints shall be retained.

Hydrants shall be installed at a maximum spacing of three hundred (300) feet with the most remote part of any building or lot no farther than three hundred (300) feet from a hydrant.

### **Allowable Hydrants**

Mueller Super Centurion 250

Clow Medallion

Kennedy Guardian K81 D

### **Valves**

Mechanical joint resilient wedge gate valve.

Cast iron, bronze-mounted, O-ring seal, bronze non-rising stems.

Valves shall open left and be tested to 500 psi with a 250 psi working pressure.

Valves shall have stainless steel bolts and nuts.

A sufficient number of valves shall be provided so that a break or other failure will not affect more than 800 feet of mains in residential areas or 600 feet of mains in other areas.

Valves shall be placed so that closure of a maximum of three (3) valves are necessary to shut down any point in the system.

### **Allowable Valves**

American Flow Control  
Clow  
Mueller  
Kennedy

### **Valve Boxes**

Valve boxes shall be adjustable, 2-piece cast iron; five and one quarter inch (5 ¼") shaft roadway-type and no-tilt drop cover with "WATER" cast into it.

Valve box extensions when necessary shall be center screw type extension threaded male at the top and female at the bottom. The extension shall be compatible with the five and one quarter inch (5 ¼") valve box.

Valve box stabilizer of PVC manufactured by Valve Box Stabilizer, Inc. or stabilizer of rubber by Valve Box Adapter II manufactured by Adaptor, Inc. for six inch (6") valves shall be provided.

Valve box must have additional upward or downward travel when adjusted to finished grade.

### **Valve Vaults**

Valve vaults are required for eight inch (8") or larger valves.

All valve vaults shall be precast reinforced concrete only.

All valve vaults shall have no more than two adjusting rings with a minimum of four inches (4") and a maximum of twelve inches (12") of adjustable rings.

Rubber adjusting rings are required for any rings that are two inches (2") in thickness, or less.

All lifting holes, joints between precast reinforced concrete sections, gaps between pipes and structures shall be tuckpointed with hydraulic cement.

All castings shall be set on bitumastic material.

Bitumastic material shall be placed between precast reinforced concrete sections.

All valve vaults shall have neoprene coated or fiberglass steps.

Valve Vault shall use a NEENAH R-1550-A frame (lid type B) with MINOOKA WATER cast on the cover or an EAST JORDAN IRON WORKS 1050 frame, heavy duty cover with WATER cast on the lid. Private water shall not be marked MINOOKA.

Valve operating nuts shall be accessible through the frame and lid.

Use five foot (5') diameter vault for 16" water valve.

Concentric cones are required on valve vaults except for pressure tap valves shall be eccentric.

All valve vaults shall be set on a six inch (6") CA-7 cushion.

### **Fire Hydrant to be Adjusted**

All barrel and stem extensions shall be of the same manufacturer as the existing hydrant. Barrel color shall match the existing hydrant and all paint nicks and scratches on the hydrant shall be touched up.

All stem extensions shall be jointed to the existing stem with stainless steel pins.

All Valve box extensions shall be the same size and type as those existing.

### **Fire Hydrant to be Relocated**

All new auxiliary valves and boxes shall be the same size and type as those existing.

All work including operation of valves and watermain shut-downs shall be coordinated with the Village of Minooka.

Disinfection shall be in accordance with AWWA latest standard for Disinfection Procedures when cutting into or Repairing Existing Mains.

### **Replacing Watermain**

The work shall be coordinated to minimize disruption of service. No disconnection from existing or connection to proposed is to be performed until the new watermain is tested and

placed into service and all work shall be performed prior to abandoning the existing watermain. Notification of interruption of service shall be made to those affected by the Contractor in writing a minimum of 24 hours in advance. The Village of Minooka Public Works Department shall approve all interruptions to service in advance. The Contractor may have to verify the existing type of materials used for exiting watermains prior to starting construction.

### **Where Services Cross Pavements**

Where an existing service is to be replaced, the existing service size shall be determined by the Contractor prior to scheduling relocation, except that no new or replacement service shall be less than one inch (1"). Where the existing service is less than one inch (1"), a reducer coupling shall be used.

### **Pressure Taps**

Stainless steel tapping sleeves can only be used for non size on size taps or taps on mains less than or equal to 12". Ductile iron pressure taps will be permitted for sizes greater than 12" and may be required by the Village.

Cut-in-Sleeves shall be MUELLER, CLOW, or Village approved equal.

All existing pipe shall be exposed and measured to assure purchase or fabrication of the proper fitting prior to existing mains being shut-down or cut. The contractor is cautioned that some existing mains may be sand-cast.

Prior to making cut-in-connections the contractor shall notify and coordinate with the **VILLAGE OF MINOOKA** on procedure, notifications to users and timing.

The connection shall be disinfected.

### **Restraining Glands**

All mechanical joint fittings, valves, fire hydrants, etc. shall be restrained with a restraining device such as Mega Lug Series 1100.

### **Tee Bolts**

Tee bolts shall be xylan coated stainless steel.

### **Concrete Thrust Blocks**

Concrete shall be Class SI.

Where horizontal bend is made, the piping shall be restrained by means of a thrust block as detailed on the drawings.



Concrete shall bear on one complete quadrant of pipe as a minimum.

**MINIMUM THRUST BLOCK AREA FT<sup>2</sup>**

| <u>Pipe Size</u> | <u>Dead End/Tee</u> | <u>90' Bend</u> | <u>45' Bend</u> | <u>22 ½' Bend</u> | <u>11 ¼' Bend</u> |
|------------------|---------------------|-----------------|-----------------|-------------------|-------------------|
| 6"               | 3.0                 | 4.0             | 2.0             | 1.0               | 1.0               |
| 8"               | 5.0                 | 7.0             | 4.0             | 2.0               | 1.0               |
| 10"              | 8.0                 | 11.0            | 6.0             | 3.0               | 2.0               |
| 12"              | 13.0                | 15.0            | 8.0             | 4.0               | 2.0               |

**Inspection During Construction**

Full time inspection may be required by the Village, which would be performed, by the Village or an authorized Village representative during the installation of water distribution system and related appurtenances including water service lines.

The Developer shall pay for the cost of inspection services by an authorized Village representative.

**Testing**

All watermain shall be pressure tested at 150 pounds per square inch (psi) for 3 hours or 100 pounds per square inch (psi) for 24 hours and allowable leakage shall be in accordance with the Standard Specifications For Water And Sewer Main Construction in Illinois, latest edition.

All watermains shall be disinfected in accordance to methods stated in AWWA Standard C651-92.

All Disinfection shall be under the direct supervision of a Licensed Village of Minooka Water Operator or designated representative.

Bacteriological samples from sample whips are required at all dead ends, at a maximum of 1,250-foot-intervals on straight through pipe runs and taken by a licensed IL EPA Water Operator employed by the Village of Minooka.

Precautions shall be followed to ensure that any of the disinfecting agents do not flow back into the line supplying water.

All watermains shall be flushed to remove any solids or contaminated material that may have become lodged in the pipe. Arrangements must be made prior to flushing with the Village Public Works Department.

All watermains shall be tested by means of representative samples from the newly installed

system for bacteriological contamination by a Certified IL EPA laboratory.

The Contractor shall reimburse all Bacteriological sampling fees to the Village. Typical cost are as follows:

Daily Bacteriological sampling rates

Sample #1.....\$50.00 each  
All following samples.....\$40.00 each

Note: Sampling costs are subject to change without notice.

**Water Service Standards**

1. ¾" Service Line

- A. MUELLER Corporation Stop, "CC" thread inlet x CTS compression outlet, H-15008  
MUELLER Curb Valve Mark II Oriseal, Minneapolis Pattern, H-15155  
MUELLER Curb Box, Minneapolis Pattern, 1 ½" upper section, H-10300-99008  
Precast Concrete Service Pad (to set the curb valve on)
  
- B. McDONALD Corporation Stop, "CC" thread inlet x CTS compression outlet, 4701Q  
McDONALD Curb Stop, 2" Minneapolis Pattern, 6104Q  
McDONALD Curb Box, Minneapolis Pattern, 1 ½" upper section, 5614  
Precast Concrete Service Pad (to set the curb valve on)
  
- C. FORD METER Corporation Stop, "CC" thread inlet x CTS compression outlet, F1000-3-Q-NL  
FORD METER Curb Stop, 2" Minneapolis Pattern, B22-33M-NL  
FORD METER Curb Box, Minneapolis Pattern, 1 ½" upper section, EMZ-XX-56  
Precast Concrete Service Pad (to set the curb valve on)

Or approved equal

2. 1" Service Line

- A. MUELLER Corporation Stop, "CC" thread inlet x CTS compression outlet, H-15008  
MUELLER Curb Valve Mark II Oriseal, Minneapolis Pattern, H-15155  
MUELLER Curb Box, Minneapolis Pattern, 1 ½" upper section, H-10300-99002  
Precast Concrete Service Pad (to set the curb valve on)
  
- B. McDONALD Corporation Stop, "CC" thread inlet x CTS compression outlet, 4701Q

McDONALD Curb Stop, 2" Minneapolis Pattern, 6104Q  
McDONALD Curb Box, Minneapolis Pattern, 1 ½" upper section, 5614  
Precast Concrete Service Pad (to set the curb valve on)

- C. FORD METER Corporation Stop, "CC" thread inlet x CTS compression outlet, F1000-4-Q-NL  
FORD METER Curb Stop, 2" Minneapolis Pattern, B22-33M-NL  
FORD METER Curb Box, Minneapolis Pattern, 1 ½" upper section, EMZ-XX-56  
Precast Concrete Service Pad (to set the curb valve on)  
Or approved equal

3. 1 ½" Service Line

- A. MUELLER Corporation Stop, "CC" thread inlet x CTS compression outlet, H-15013  
MUELLER Curb Valve 300 Ball, Minneapolis Pattern, B-25155  
MUELLER Curb Box, Minneapolis Pattern, 1 ½" upper section, H-10300-99002  
SMITH BLAIR Nylon coated 317 Saddle, Double Strap, Tapped "CC" thread  
ROCKWELL Nylon coated  
Precast Concrete Service Pad (to set the curb valve on)

- B. McDONALD Corporation Stop, "CC" thread inlet x CTS compression outlet, 4701Q  
McDONALD Curb Stop 6104Q, 2" Minneapolis Pattern  
McDONALD Curb Box, Minneapolis Pattern, 1 ½" upper section, 5615

- C. FORD METER Corporation Stop, "CC" thread inlet x CTS compression outlet, FB600-6-Q-NL  
FORD METER Curb Stop, 2" Minneapolis Pattern, B22-33M-NL  
FORD METER Curb Box, Minneapolis Pattern, 1 ½" upper section, EMZ-XX-56  
Precast Concrete Service Pad (to set the curb valve on)  
SMITH BLAIR Nylon coated 317 Saddle, Double Strap, Tapped "CC" thread  
Precast Concrete Service Pad (to set the curb valve on)

Or approved equal

4. 2" Service Line

- A. MUELLER Corporation Stop H-15013  
MUELLER Curb Valve 300 Ball, Minneapolis Pattern, B-25155  
MUELLER Curb Box, Minneapolis Pattern, H-10300-99002  
SMITH BLAIR Nylon coated 317 Saddle, Double Strap, Tapped "CC" thread  
Precast Concrete Service Pad (to set the curb valve on)

- B. McDONALD Corporation Stop, "CC" thread inlet x CTS compression outlet, 4701Q

McDONALD Curb Stop, 2" Minneapolis Pattern, 6104Q  
McDONALD Curb Box, Minneapolis Pattern, 1 ½" upper section, 5615  
SMITH BLAIR Nylon coated 317 Saddle, Double Strap, Tapped "CC" thread  
Precast Concrete Service Pad (to set the curb valve on)

- C. FORD METER Corporation Stop, "CC" thread inlet x CTS compression outlet, F1000-7-Q-NL  
FORD METER Curb Stop, 2" Minneapolis Pattern, B22-33M-NL  
FORD METER Curb Box, Minneapolis Pattern, 1 ½" upper section, EMZ-XX-56  
FORD METER Nylon Coated FCD202 Saddle, Double Strap, Tapped CC" thread  
Precast Concrete Service Pad (to set the curb valve on)

Or approved equal

### **Meter Pit**

A meter pit shall be used for the purpose of irrigation systems in residential or small commercial buildings to alleviate the sanitary sewer charges or a building that has no accessibility or location to install a water meter.

#### **Plastic Meter Pit Setter**

Shall be FORD code number PDVHH-288-18-48-NL plastic pit setter with a total bury depth of sixty inches (60").

#### **Meter Pit Cover**

Shall be a FORD W32-TT, cast iron meter pit cover with a double lid for cold climates and a pentagon-style locking nut to secure the lid.

Shall be a McDONALD 74M32 WT, cast iron meter pit cover with a double lid for cold climates and a pentagon-style locking nut to secure the lid.

#### **Meter Set**

Shall be a FORD angle key valve on the inlet side and an angle dual check valve on the outlet side to accommodate a typical touch read residential meter.

# VALVE VAULT FOR WATERMAIN VALVES 8" AND LARGER

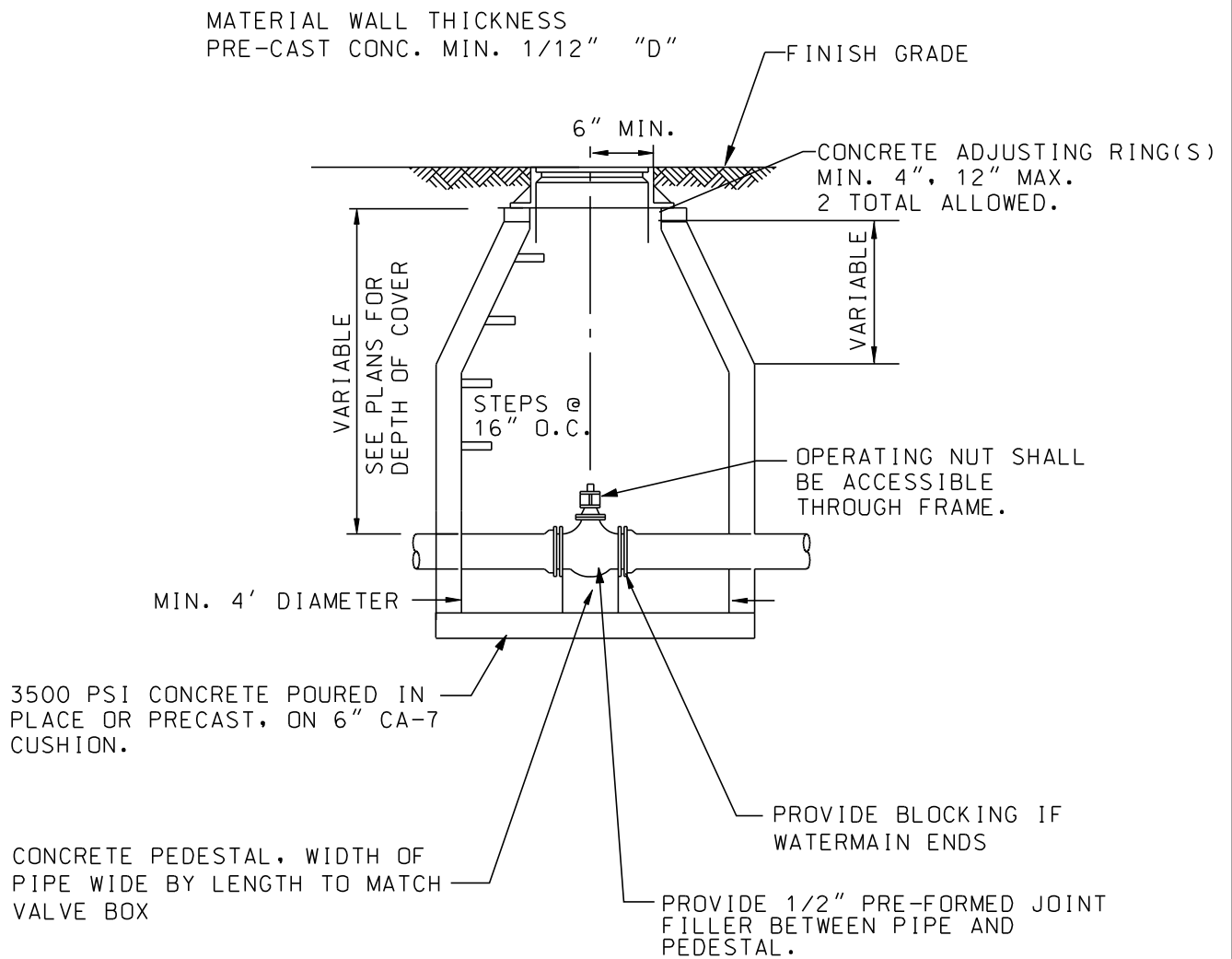

# VALVE VAULT FRAME AND COVER

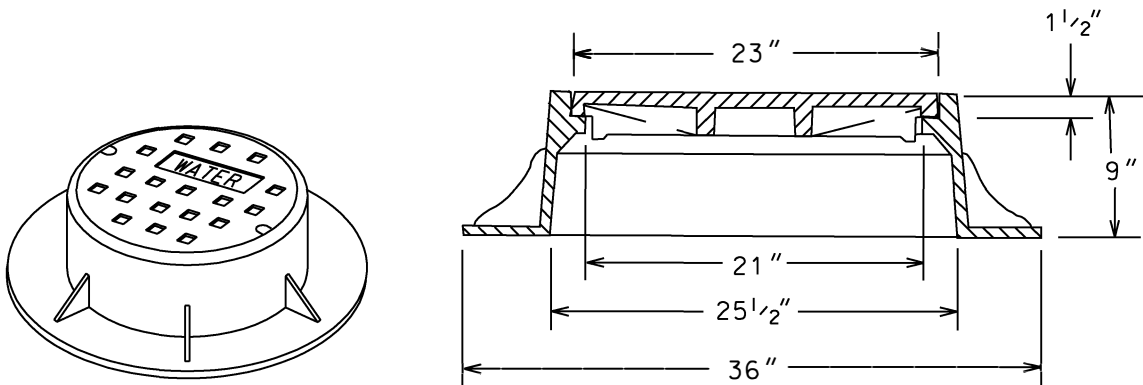

- 1.) THE FRAME AND LID SHALL BE EJIW 1050 FRAME WITH M1 GRATE OR NEENAH R-1550-A FRAME WITH TYPE B LID. TWO CONCEALED PICKHOLES.
- 2.) THE LID SHALL HAVE RAISED LETTERS 'WATER' AND 'MINOOKA'.
- 3.) THE FRAME AND LID SHALL BE SET ON A MASTIC BED WITH ALL GAPS TUCKPOINTED.

\*\* ALL DIMENSIONS ARE FOR THE NEENAH MODELS.  
EJIW DIMENSIONS MAY VARY.

# TYPICAL HYDRANT INSTALLATION

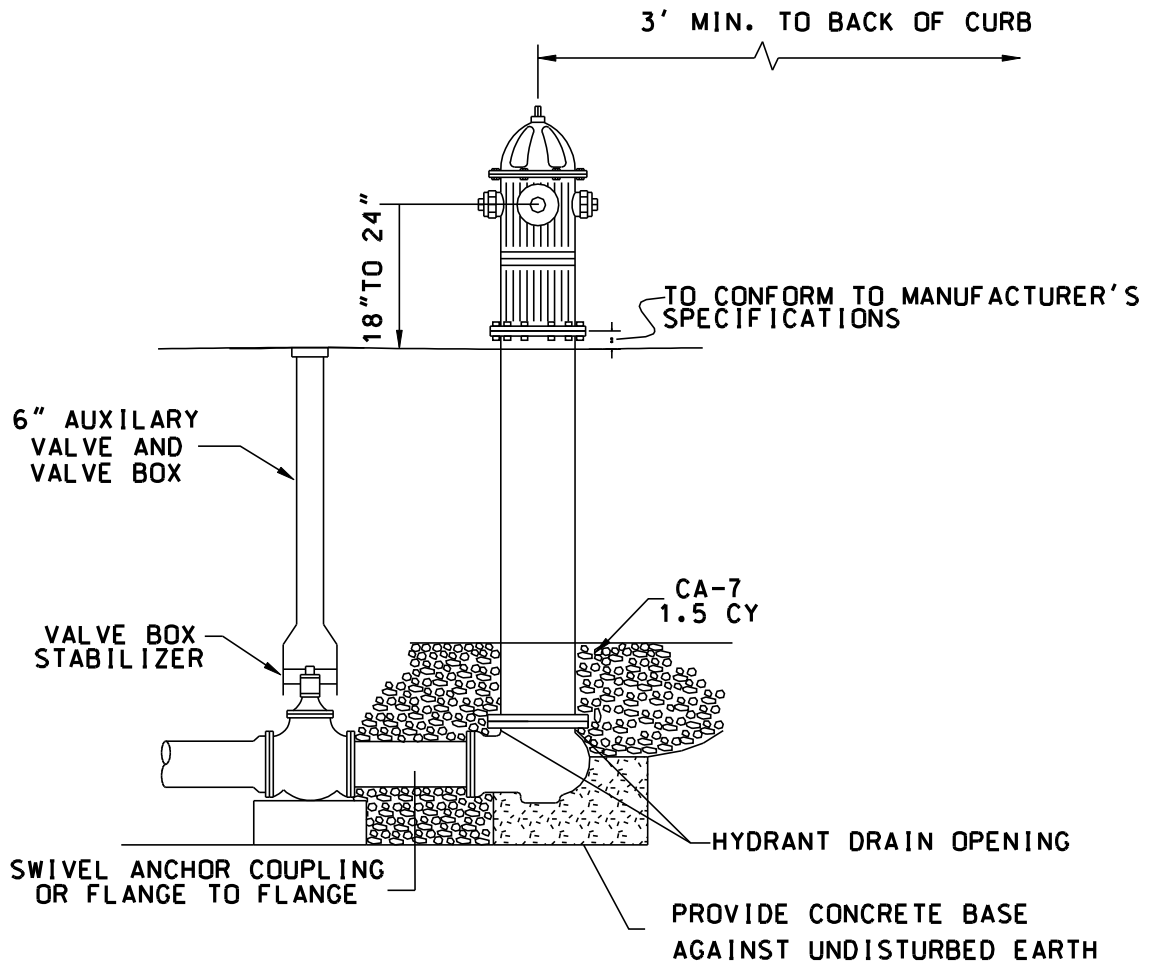

NOTE: CONCRETE BASE AND BLOCKING MATERIAL SHALL NOT BLOCK NOR OBSTRUCT HYDRANT DRAIN AS SHOWN IN AWWA MANUAL M 17

# VALVE BOX INSTALLATION FOR 2" TO 6" WATER SERVICES ONLY AND/OR HYDRANT AUXILIARY VALVES

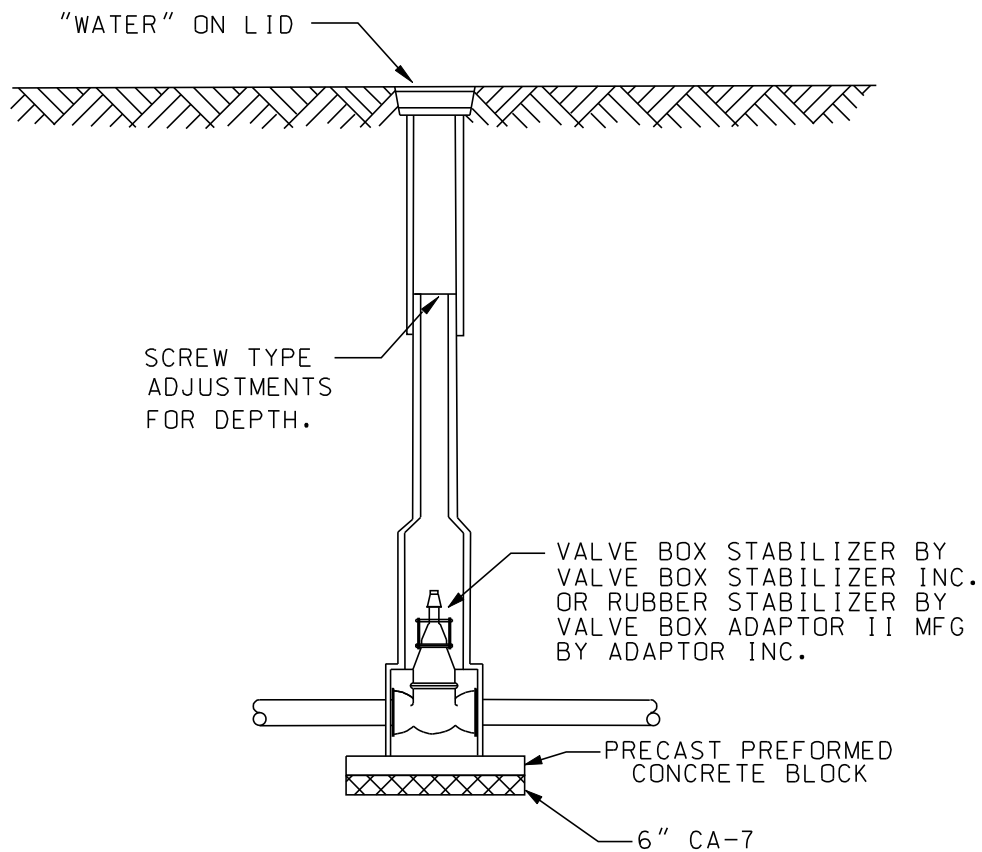



# VALVE BOX OPERATING NUT EXTENSION

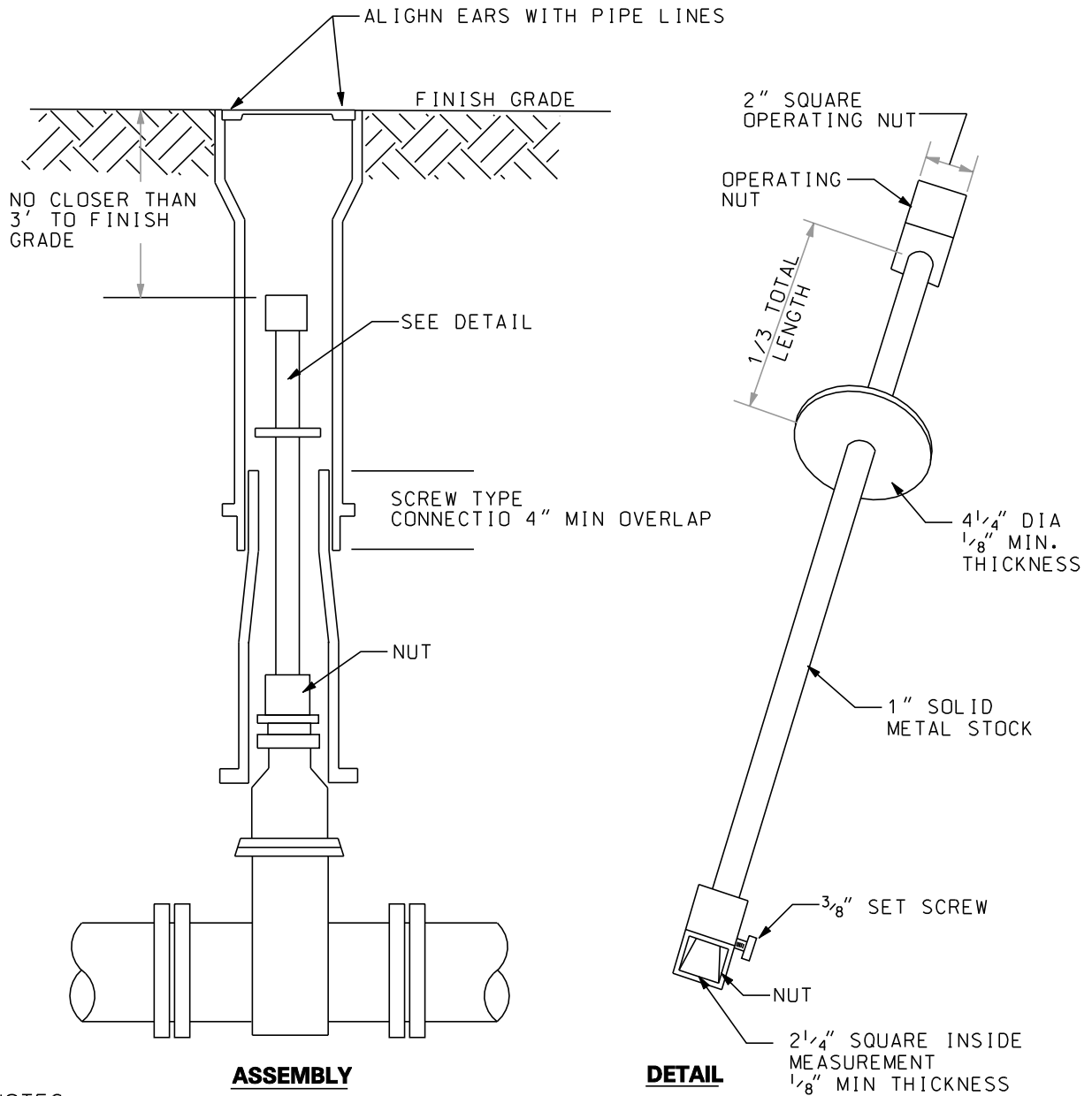

## NOTES

1. EXTENSIONS ARE REQUIRED WHEN THE VALVE NUT IS MORE THAN 6 FEET BELOW FINISHED GRADE.
2. ONLY ONE EXTENSION, MINIMUM OF 3 FEET LONG TO BE USED PER VALVE.
3. ALL EXTENSIONS ARE TO BE MADE OF STEEL AND PAINTED WITH TWO COATS OF METAL PAINT. NO FIELD-FABRICATED EXTENSIONS.
4. VALVE BOX COVER SHALL BE LABELED WATER.

# SERVICE TAP 2" DIAMETER OR LESS

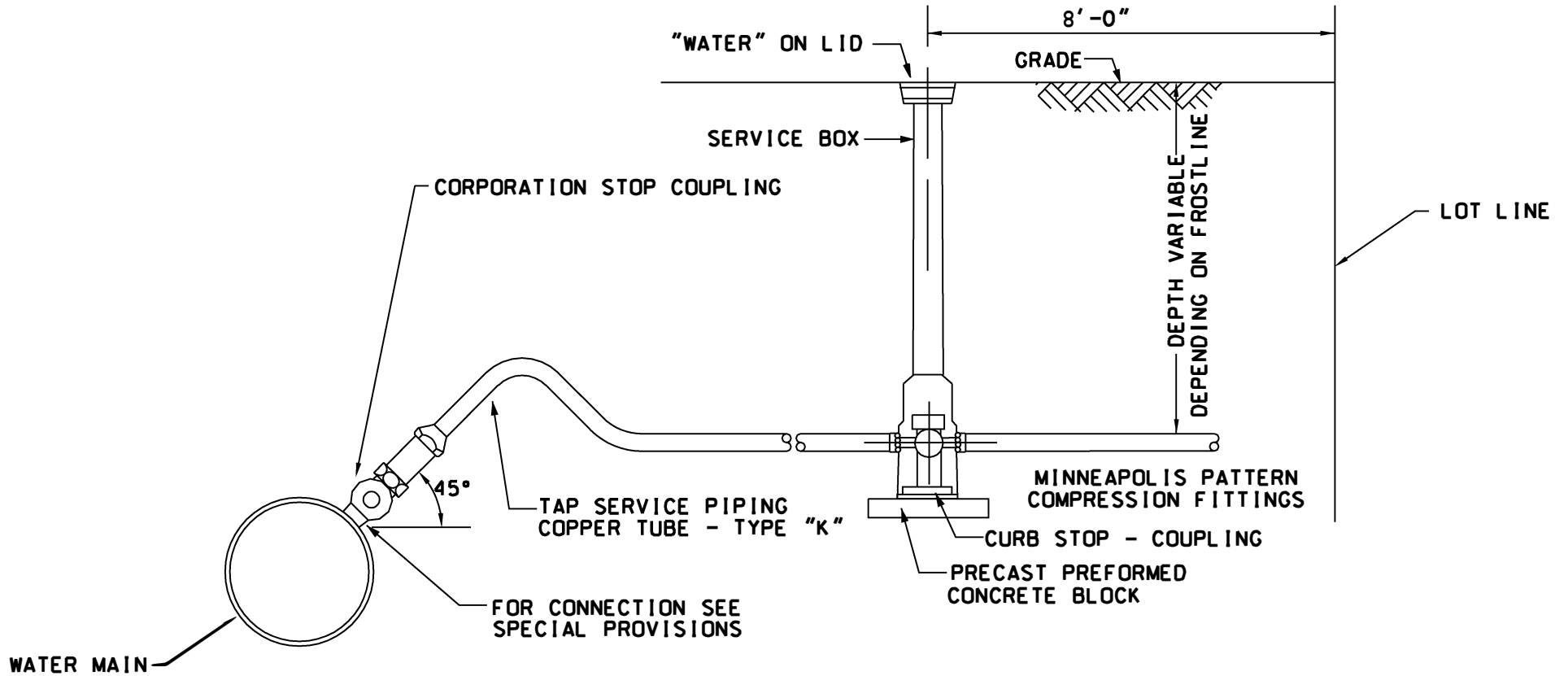

**MINOOKA STANDARD**

VERSION 1.0

# THRUST BLOCK INSTALLATIONS

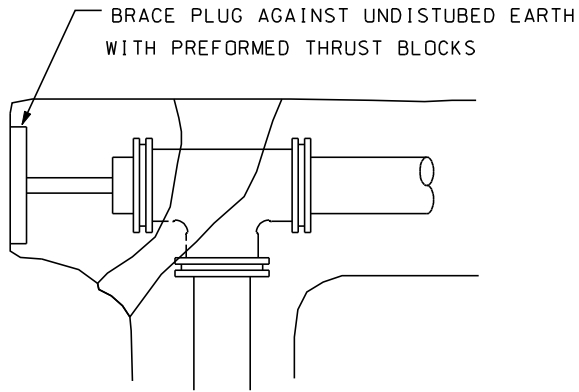

**PLUGGED TEE**

BRACE PLUG AGAINST UNDISTUBED EARTH  
WITH PREFORMED THRUST BLOCKS

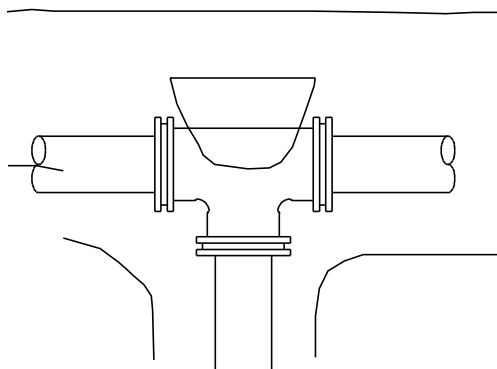
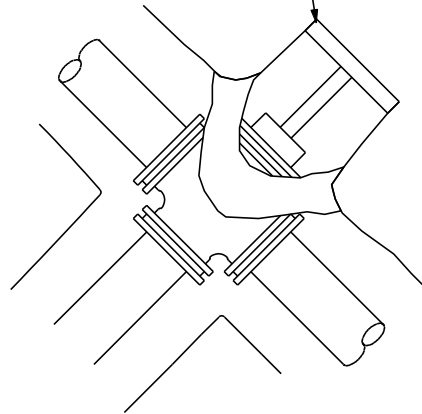

**TEE**

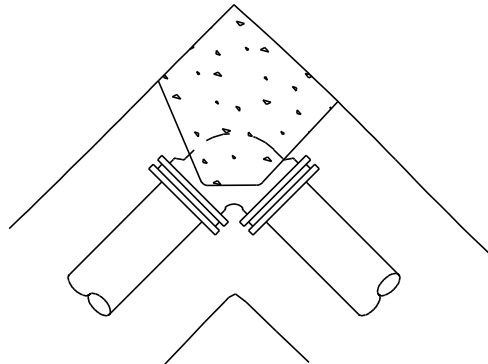

**90° ELBOW**

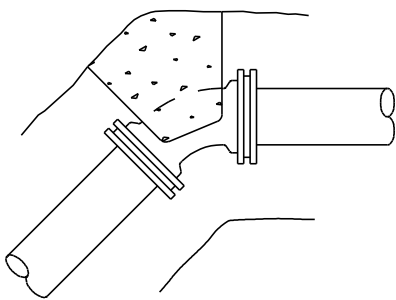

**VERTICAL BEND**

**NOTE:**

ALL BLOCKS BEAR AGAINST UNDISTURBED EARTH. ARROWS INDICATE DIRECTION OF THRUST. ALL BLOCKS TO BE 3000 PSI CONCRETE. ALL FITTINGS SHOWN IN PLAN EXCEPT VERTICAL BEND. MEG-A-LUG RETAINER GLANDS SHALL BE USED WHERE WATERMAIN CROSSES BENEATH OTHER PIPE. CLASS 56 DUCTILE IRON FITTINGS SHALL BE USED BENEATH RAILROADS AND COLLECTOR OR ARTERIAL STREETS.

# WATERMAIN TRENCH

IDENTIFICATION OF WHERE  
SELECT GRANULAR MATERIAL  
IS REQUIRED.

TERMINOLOGY, DIMENSIONS  
AND TYPE OF SELECT  
MATERIAL, WHEN REQUIRED.

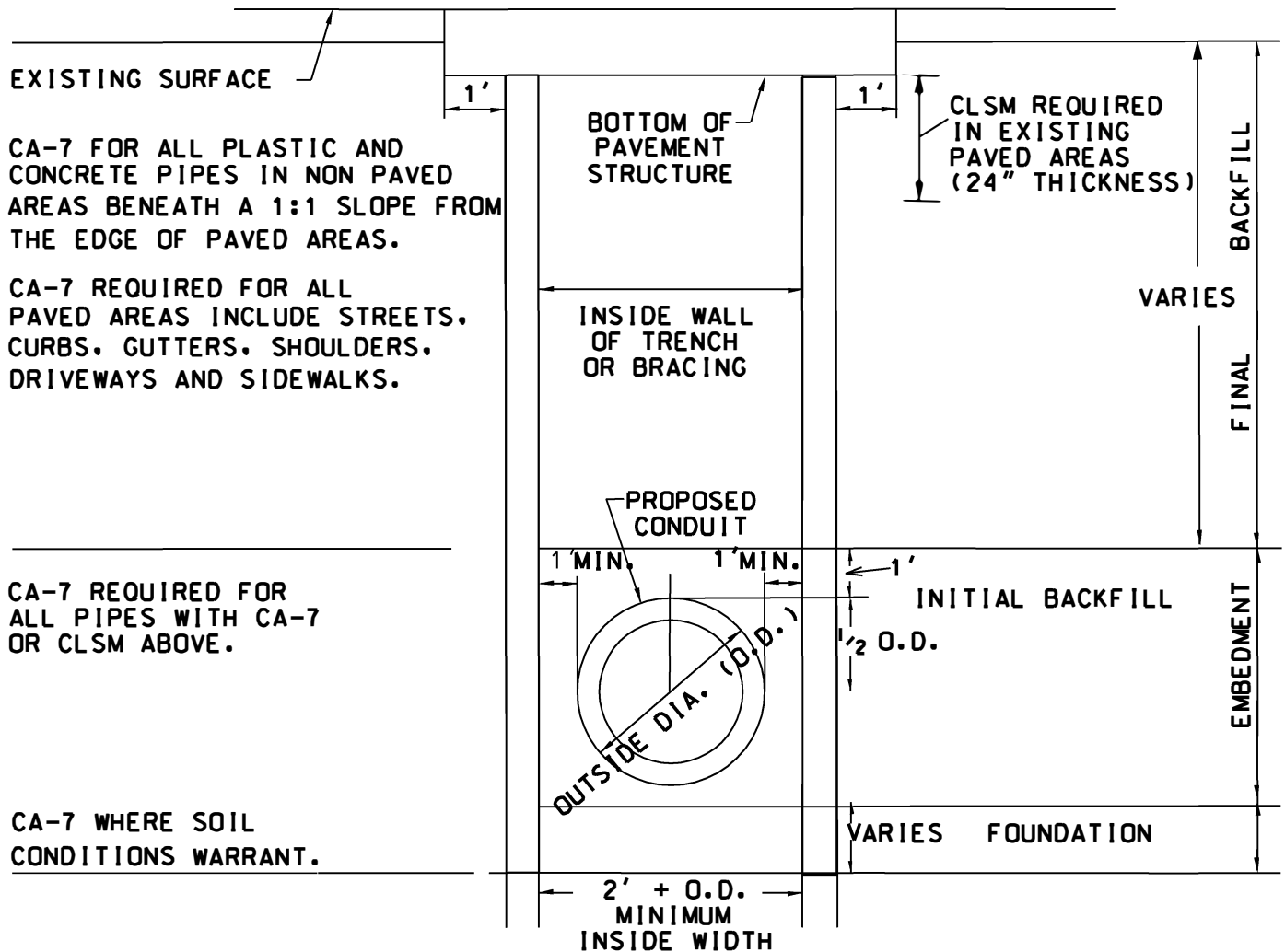

EXISTING SURFACE

CA-7 FOR ALL PLASTIC AND CONCRETE PIPES IN NON PAVED AREAS BENEATH A 1:1 SLOPE FROM THE EDGE OF PAVED AREAS.

CA-7 REQUIRED FOR ALL PAVED AREAS INCLUDE STREETS, CURBS, GUTTERS, SHOULDERS, DRIVEWAYS AND SIDEWALKS.

CA-7 REQUIRED FOR ALL PIPES WITH CA-7 OR CLSM ABOVE.

CA-7 WHERE SOIL CONDITIONS WARRANT.

NOTE: MIN 4" BEDDING REQUIRED  
HAUNCHING AND BEDDING  
SHALL  
BE CA7 OR 3/8" CHIPS